

# EECS 498: Electric Machinery and Drives Winter 2010



**Tesla Roadster**

Each of these systems contains: an electric machine operating either as a motor, a generator, or both; a power electronic circuit which interfaces the machine to a power supply or an electrical system; and a controller which measures electrical and mechanical quantities and uses this information to control the power electronic circuitry.

In the struggle to address today's energy and environmental challenges, many potential solutions require electro-mechanical energy conversion. Examples include electric propulsion drives for electric and hybrid electric vehicles, generators for wind turbines, and high-speed motor/alternators for flywheel energy storage systems.



**Wind Turbines**

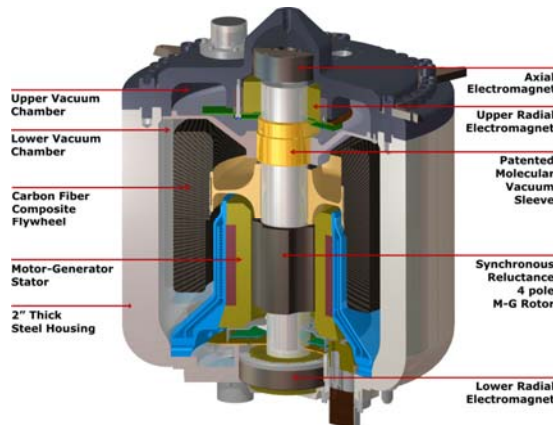

**Flywheel Energy Storage**

In this course we will cover fundamental electromechanical, power electronic, and control theory in the context of electric drive systems. The capabilities and limitations of different types of electric machines (e.g., permanent magnet, induction) in various drive applications will be covered. MATLAB® Simulink® models will be used throughout the course to give students exposure to the dynamic behavior of these systems.

**Lectures:** Tuesday & Thursday 12-1:30  
Wednesday 12-1

**Instructor:** Prof. Heath Hofmann  
([hofmann@eecs.umich.edu](mailto:hofmann@eecs.umich.edu))

**Prerequisites:** EECS 216 (or equivalent; material will also be accessible to students in non-EE disciplines)

